

Nidec

Power

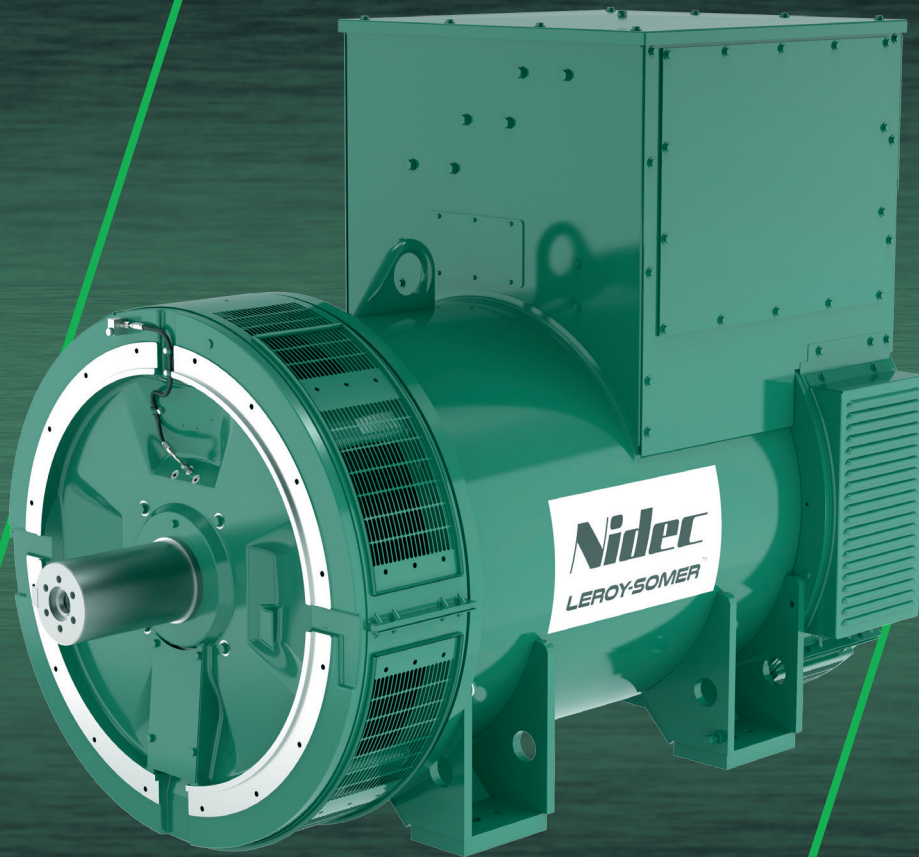

LSA 52.3

Low Voltage Alternator - 4 poles

1 860 to 2 750 kVA - 50 Hz / 2 230 to 3 400 kVA - 60 Hz

Electrical and mechanical data

LEROY-SOMER[™]

The best of performance

The Leroy-Somer™ LSA 52.3 alternator has been designed to offer you the best power generation performances. With its meticulous design and optimized architecture, the LSA 52.3 strikes the perfect balance between compactness, reliability, performance and longevity. Whatever your application, the Leroy-Somer™ LSA 52.3 alternator will meet your needs and will adapt to all situations.

Standards

The Leroy-Somer™ LSA 52.3 alternator meets all key international standards and regulations such as IEC 60034, NEMA MG 1.32-33, ISO 8528-3, CSA C22.2 n°100-14, UL 1446, UL 1004-1 and UL 1004-4. EC, UKCA, CMIM, CSA, UL 1446, UL recognized and UL listed declarations and certifications are available for the LSA 52.3. The standards IEC 61000-6-2, IEC 61000-6-3, IEC 61000-6-4, VDE 0875G, VDE 0875N and EN 55011 allow compliance with group 1 class A for the European zone. The Leroy-Somer™ LSA 52.3 alternator is designed, manufactured and marketed in an ISO 9001 and ISO 14001 quality assurance environment.

Electrical characteristics and performances

- Class H insulation
- 2/3 pitch winding, standard 6-wire (6S)
- Voltage range:
 - 50 Hz: 380V - 400V - 415V
 - 60 Hz: 440V - 480V
- High efficiency and motor starting capacity
- Other voltages are possible with optional adapted windings:
 - 50 Hz: 440V (no. 7), 500V (no. 9), 600V (no. 23), 690V (no. 52)
 - 60 Hz: 380V and 416V (no. 8), 600V (no. 9), 690V (no. 22)

Excitation and regulation system

Excitation system			Regulation options		
AVR	AREP + PMI	PMG	C.T. Current transformer for paralleling	Mains paralleling	Remote voltage potentiometer
D550	Standard	Option	√	√	√

3-phase sensing is included as a standard with digital regulators.

Protection system and options

- Degree of protection: IP 23
- Complete winding protection for clean environments with relative humidity ≤ 95 %, including indoor marine environments
- Options:
 - Filters on air inlet (derating 5%)
 - Filters on air inlet and air outlet (IP 44) (derating 10%)
 - Reinforced winding protection for harsh environments and relative humidity greater than 95% (derating 6%)
 - Space heater
 - Protection or metering CTs
 - Thermal protection for stator winding and/or bearings (PT100)

Mechanical construction

- Compact and rigid assembly to better withstand generator vibrations
- Steel frame
- Cast iron flanges and shields
- Two-bearing and single-bearing versions designed to be suitable for engines on the market
- Half-key balancing
- Regreasable bearings
- Clockwise rotation in standard

Terminal box design

- Easy access to the voltage regulator and to the connections
- Possible inclusion of accessories for paralleling, protection and measurement

General characteristics

Insulation class	H	Excitation system	AREP + PMI
Winding pitch	2/3 (wind. 6S)	AVR type	D550
Number of wires	6	Voltage regulation (*)	± 0.25%
Protection	IP 23	Short-circuit current	300% (3 IN) : 10s
Altitude	≤ 1 000 m	Total Harmonic Distortion THD (**) in no-load	< 4%
Overspeed	2 250 R.P.M.	Waveform: NEMA = TIF (**)	< 50
Air flow	2.5 m³/s (50 Hz) - 2.8 m³/s (60 Hz)	Waveform: I.E.C. = THF (**)	< 2%

(*) steady state (**) between phases

Ratings 50 Hz - 1 500 R.P.M.

kVA / kW - P.F. = 0.8												
Duty/T°C	Continuous duty/40°C			Continuous duty/40°C			Stand-by/40°C			Stand-by/27°C		
Class/T°K	H/125°K			F/105°K			H/150°K			H/163°K		
Phase	3 ph.			3 ph.			3 ph.			3 ph.		
Y	380V	400V	415V	380V	400V	415V	380V	400V	415V	380V	400V	415V
LSA 52.3 S5 kVA	1 860	1 860	1 860	1 696	1 696	1 696	1 953	1 953	1 953	2 046	2 046	2 046
kW	1 488	1 488	1 488	1 357	1 357	1 357	1 562	1 562	1 562	1 637	1 637	1 637
LSA 52.3 S6 kVA	2 000	2 000	2 000	1 824	1 824	1 824	2 100	2 100	2 100	2 200	2 200	2 200
kW	1 600	1 600	1 600	1 459	1 459	1 459	1 680	1 680	1 680	1 760	1 760	1 760
LSA 52.3 S7 kVA	2 200	2 200	2 200	2 006	2 006	2 006	2 310	2 310	2 310	2 420	2 420	2 420
kW	1 760	1 760	1 760	1 605	1 605	1 605	1 848	1 848	1 848	1 936	1 936	1 936
LSA 52.3 L9 kVA	2 360	2 360	2 360	2 152	2 152	2 152	2 478	2 478	2 478	2 596	2 596	2 596
kW	1 888	1 888	1 888	1 722	1 722	1 722	1 982	1 982	1 982	2 077	2 077	2 077
LSA 52.3 L12 kVA	2 560	2 560	2 560	2 335	2 335	2 335	2 688	2 688	2 688	2 816	2 816	2 816
kW	2 048	2 048	2 048	1 868	1 868	1 868	2 150	2 150	2 150	2 253	2 253	2 253
LSA 52.3 UL16 kVA	2 750	2 750	2 750	2 508	2 508	2 508	2 888	2 888	2 888	3 025	3 025	3 025
kW	2 200	2 200	2 200	2 006	2 006	2 006	2 310	2 310	2 310	2 420	2 420	2 420

Ratings 60 Hz - 1 800 R.P.M.

kVA / kW - P.F. = 0.8										
Duty/T°C	Continuous duty/40°C			Continuous duty/40°C			Stand-by/40°C		Stand-by/27°C	
Class/T°K	H/125°K			F/105°K			H/150°K		H/163°K	
Phase	3 ph.			3 ph.			3 ph.		3 ph.	
Y	440V	480V		440V	480V		440V	480V	440V	480V
LSA 52.3 S5 kVA	2 046	2 232		1 866	2 036		2 149	2 344	2 250	2 455
kW	1 637	1 786		1 493	1 629		1 719	1 875	1 800	1 964
LSA 52.3 S6 kVA	2 200	2 400		2 007	2 189		2 310	2 520	2 420	2 640
kW	1 760	1 920		1 606	1 751		1 848	2 016	1 936	2 112
LSA 52.3 S7 kVA	2 420	2 640		2 207	2 408		2 541	2 772	2 662	2 904
kW	1 936	2 112		1 766	1 926		2 033	2 218	2 130	2 323
LSA 52.3 L9 kVA	2 596	2 832		2 368	2 583		2 726	2 974	2 855	3 115
kW	2 077	2 266		1 894	2 066		2 181	2 379	2 284	2 492
LSA 52.3 L12 kVA	2 850	3 250		2 599	2 964		2 993	3 413	3 135	3 575
kW	2 280	2 600		2 079	2 371		2 394	2 730	2 508	2 860
LSA 52.3 UL16 kVA	3 100	3 400		2 827	3 101		3 255	3 570	3 410	3 740
kW	2 480	2 720		2 262	2 481		2 604	2 856	2 728	2 992

Efficiencies 400V - 50 Hz (--- P.F.: 0.8) (— P.F.: 1)

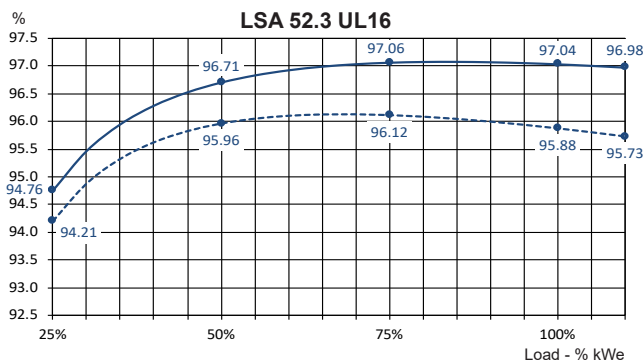
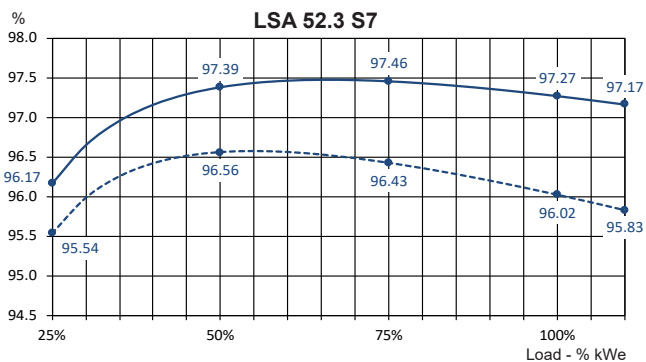
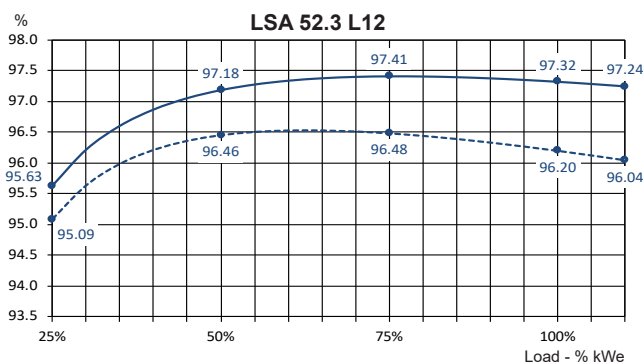
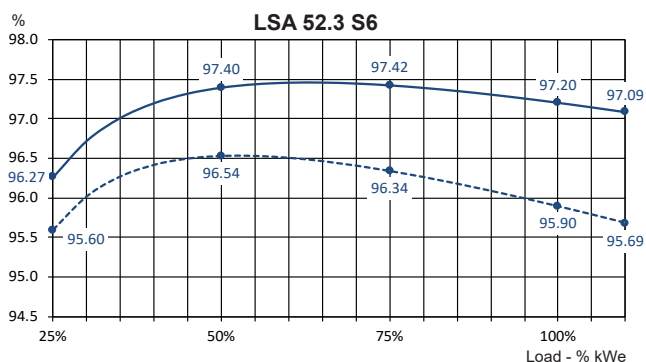
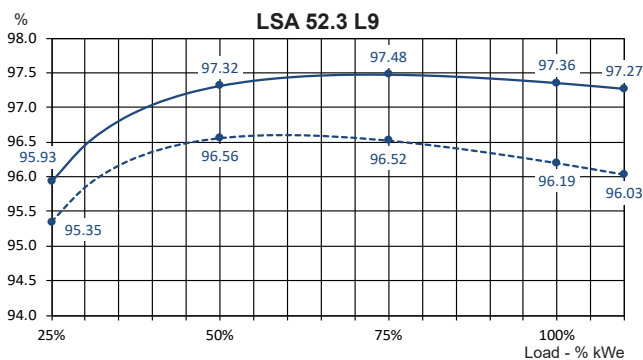
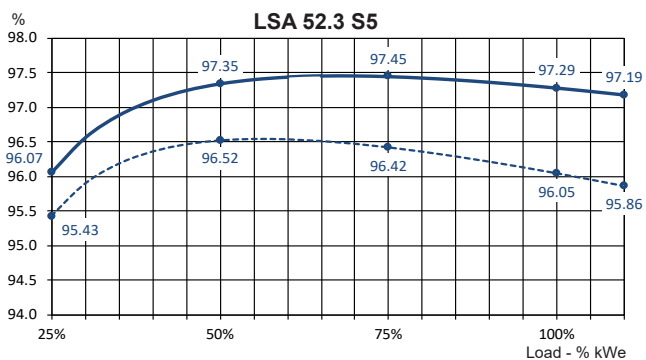

Reactances (%). Time constants (ms) - Class H / 400 V

	S5	S6	S7	L9	L12	UL16
Kcc Short-circuit ratio	0.35	0.32	0.35	0.39	0.42	0.51
Xd Direct-axis synchronous reactance unsaturated	367	380	376	344	313	267
Xq Quadrature-axis synchronous reactance unsaturated	187	194	192	175	160	136
T'do No-load transient time constant	2 760	2 760	2 870	2 990	2 760	2 920
X'd Direct-axis transient reactance saturated	28.7	30.9	28.9	26.1	23.6	20.3
T'd Short-circuit transient time constant	254	264	260	267	245	261
X''d Direct-axis subtransient reactance saturated	15	16.4	14.8	13.2	12.1	10.5
T''d Subtransient time constant	23	23	22	22	13	14
X''q Quadrature-axis subtransient reactance saturated	15.6	16.9	15.4	13.7	12.5	10.8
X0 Zero sequence reactance	2.3	2.5	2.6	2.5	2.7	2.6
X2 Negative sequence reactance saturated	15.3	16.7	15.1	13.4	12.3	10.6
Ta Armature time constant	28	28	28	28	29	30

Other class H/400 V data

io (A) No-load excitation current	1.2	1.2	1.2	1.2	1.3	1.4
ic (A) On-load excitation current	4.4	4.7	4.6	4.4	4.1	3.9
uc (V) On-load excitation voltage	45	47	47	44	42	38
kW No-load losses	15	15	17	20	24	26
kW Heat dissipation	68	76	79.5	79.2	81	100

Transient voltage variation at load inrush: 400V - 50 Hz

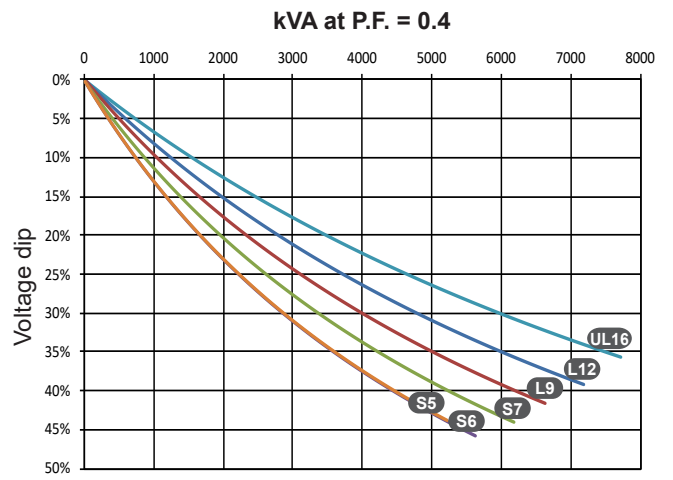
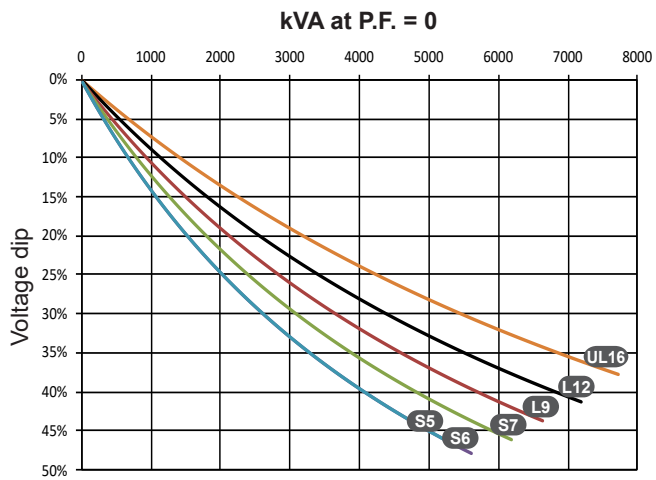
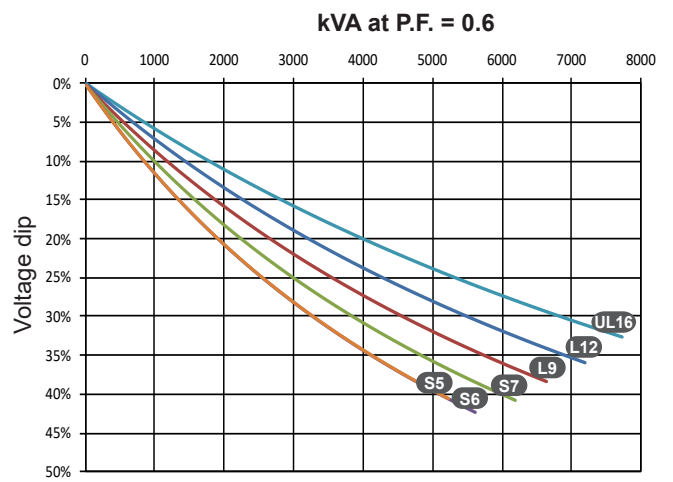
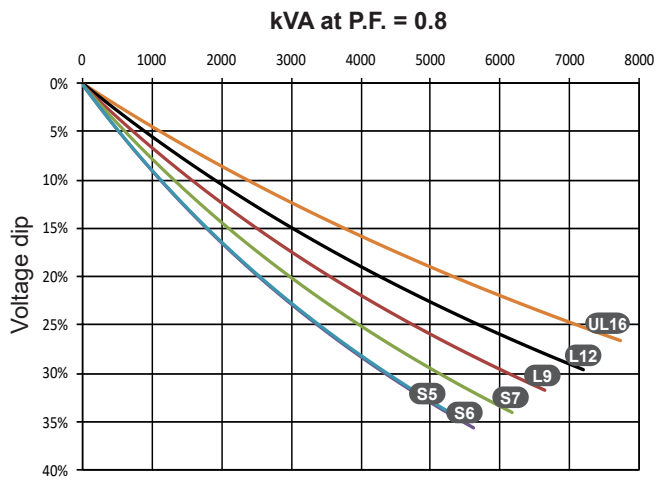

Transient voltage variation at load rejection: 400V - 50 Hz

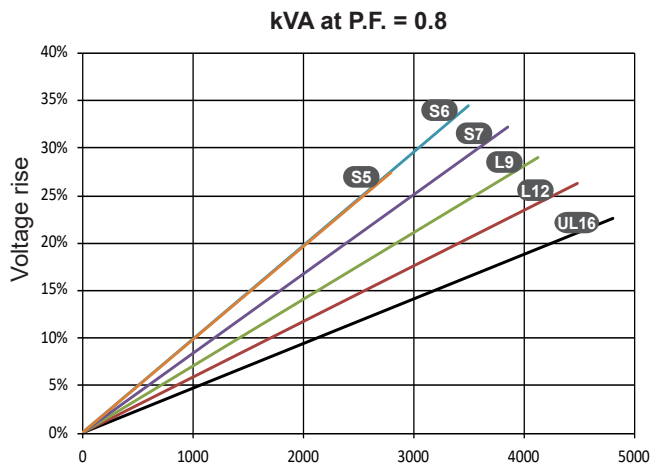

Efficiencies 480V - 60 Hz (--- P.F.: 0.8) (— P.F.: 1)

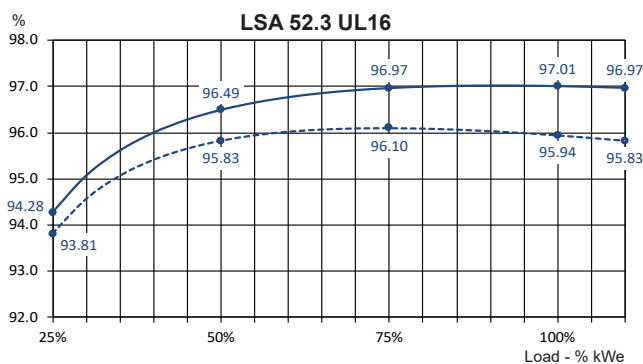
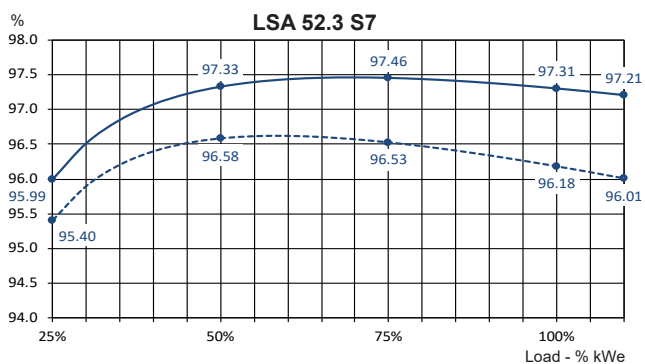
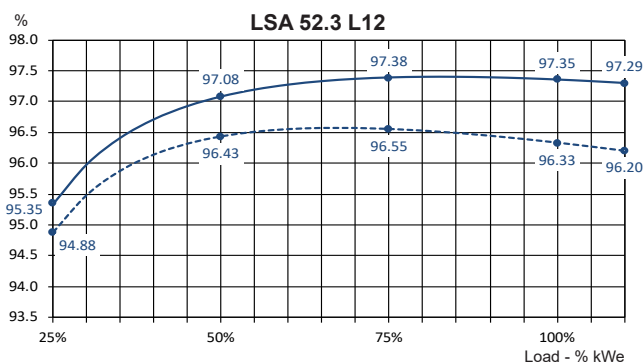
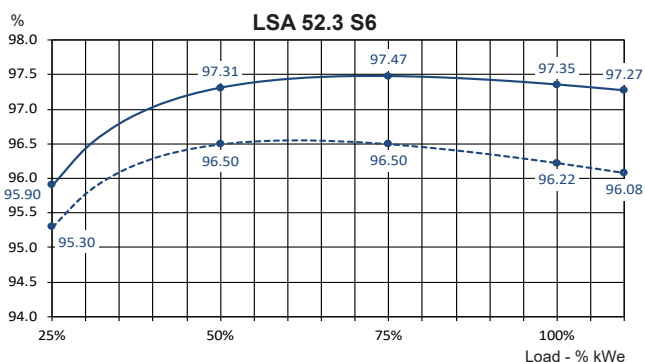
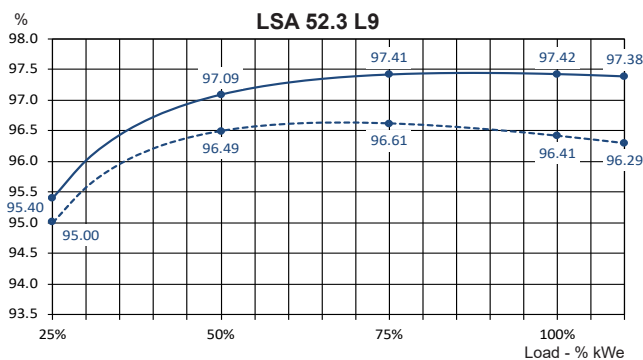
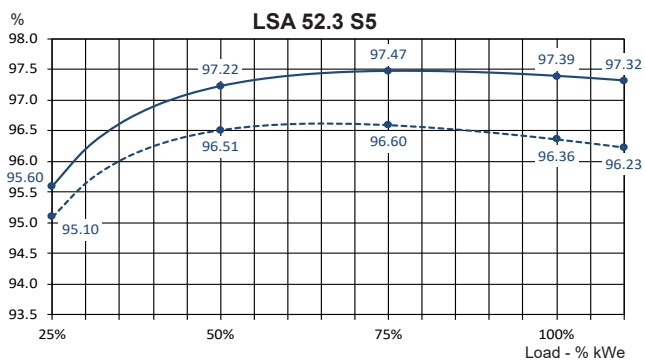

Reactances (%). Time constants (ms) - Class H / 480 V

	S5	S6	S7	L9	L12	UL16
Kcc Short-circuit ratio	0.35	0.32	0.35	0.39	0.40	0.49
Xd Direct-axis synchronous reactance unsaturated	367	380	376	344	331	275
Xq Quadrature-axis synchronous reactance unsaturated	187	194	192	175	169	140
T'do No-load transient time constant	2 760	2 760	2 870	2 990	2 760	2 920
X'd Direct-axis transient reactance saturated	28.7	30.9	28.9	26.1	25	20.9
T'd Short-circuit transient time constant	254	265	260	267	245	261
X''d Direct-axis subtransient reactance saturated	15	16.4	14.8	13.2	12.8	10.8
T''d Subtransient time constant	23	23	22	22	13	14
X''q Quadrature-axis subtransient reactance saturated	15.6	16.9	15.4	13.7	13.2	11.1
X0 Zero sequence reactance	2.3	2.6	2.6	2.5	2.9	2.7
X2 Negative sequence reactance saturated	15.3	16.7	15.1	13.4	13	11
Ta Armature time constant	28	28	28	28	29	30

Other class H/480 V data

io (A) No-load excitation current	1.1	1.1	1.2	1.2	1.2	1.3
ic (A) On-load excitation current	4.2	4.5	4.5	4.2	4.2	3.7
uc (V) On-load excitation voltage	43	46	45	43	42	36
kW No-load losses	21	21	24	28	33	36
kW Heat dissipation	73	82	86	87	96	120

Transient voltage variation at load inrush: 480V - 60 Hz

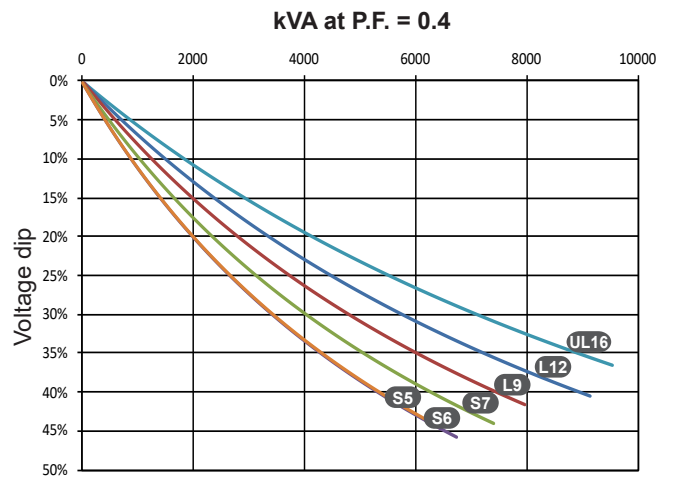
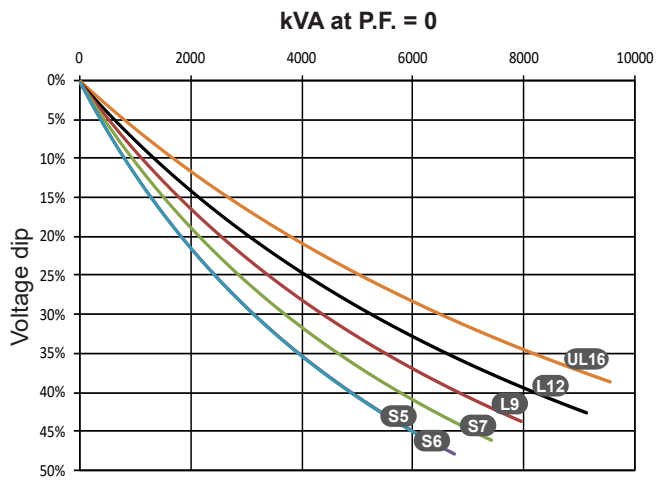
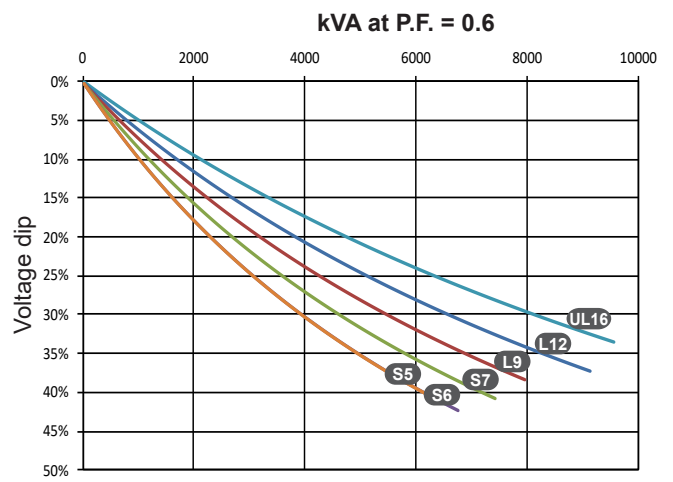
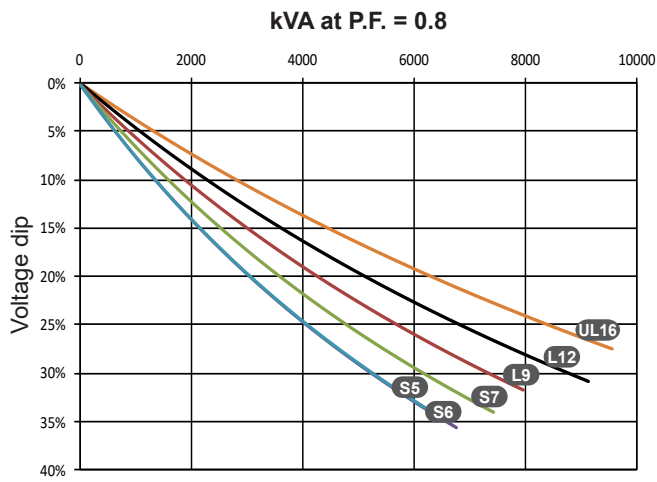

Transient voltage variation at load rejection: 480V - 60 Hz

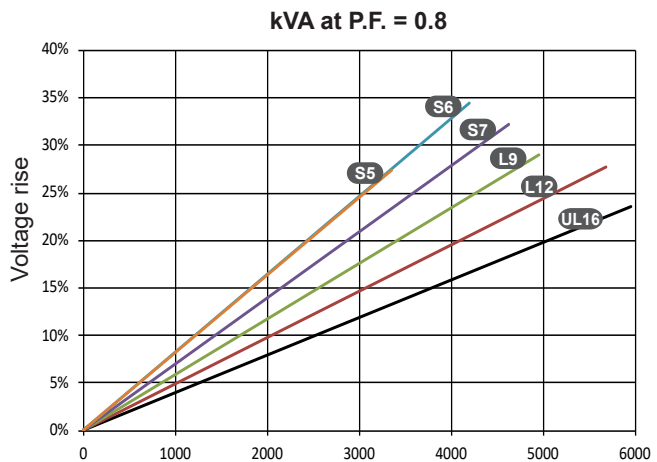

Short-circuit curves at rated speed (star connection Y)

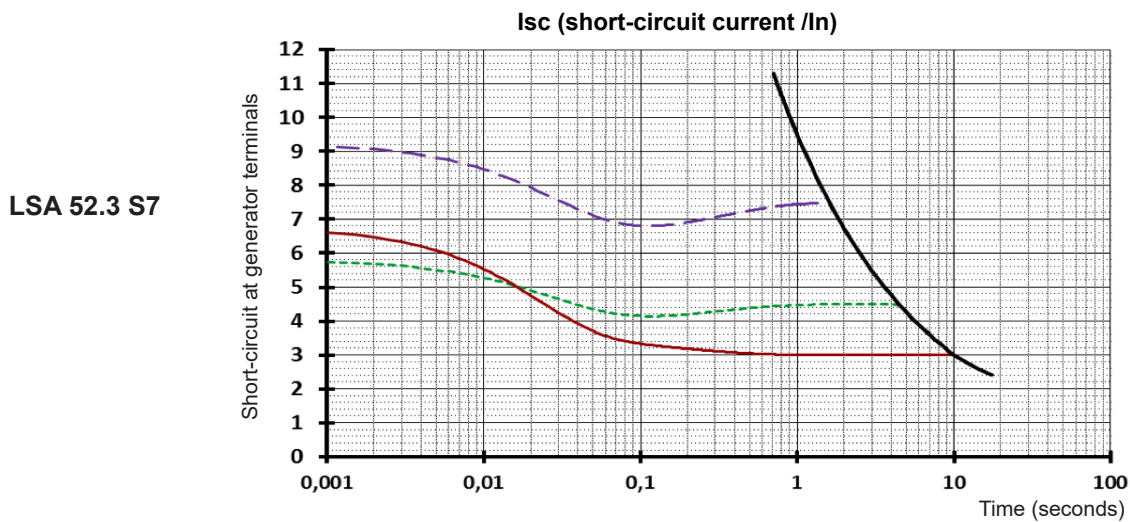
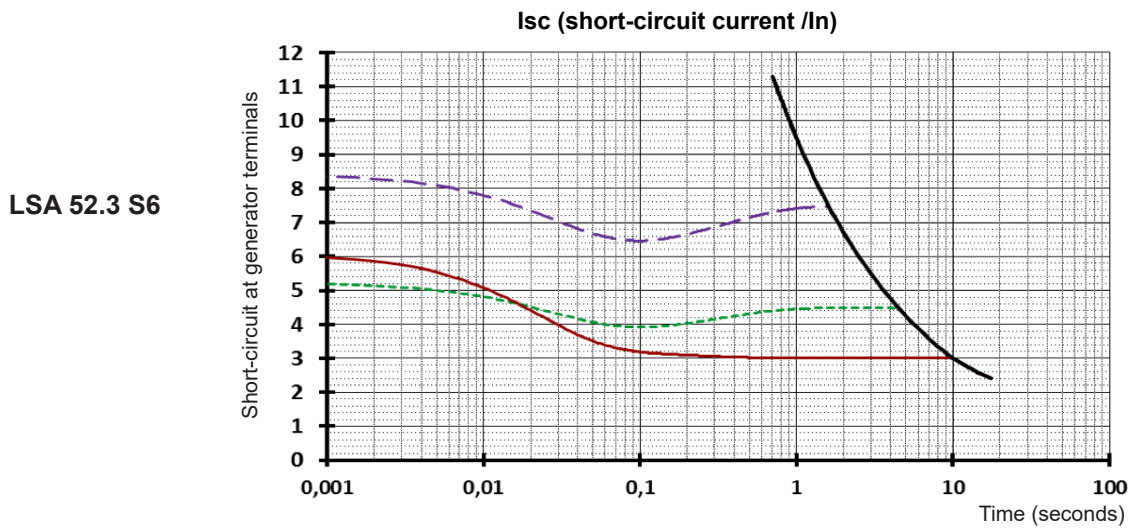
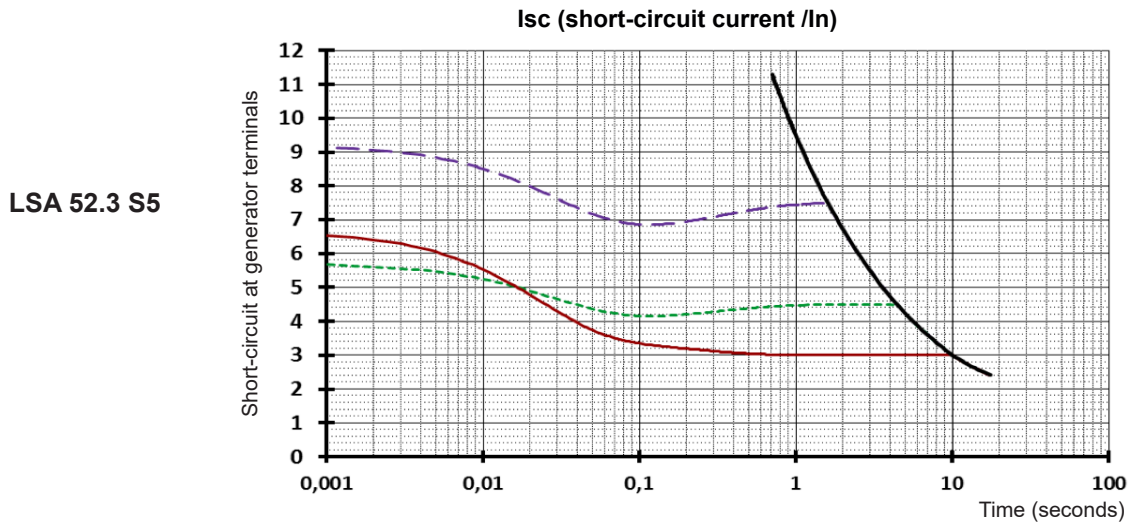

- Symmetrical phase to neutral short-circuit
- - - Symmetrical two-phase short-circuit
- Symmetrical three-phase short-circuit
- Thermal limit curve

Short-circuit curves at rated speed (star connection Y)

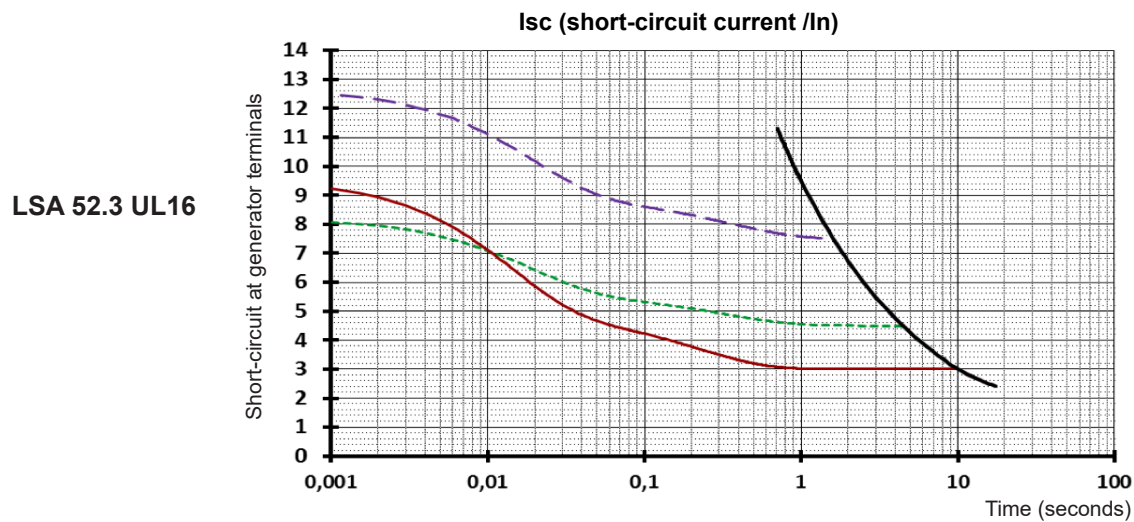
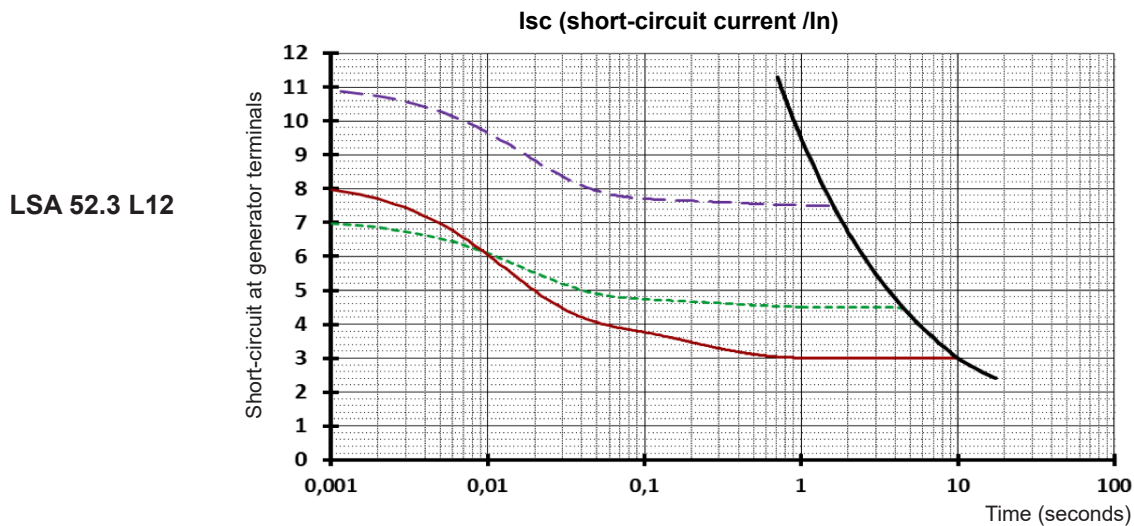
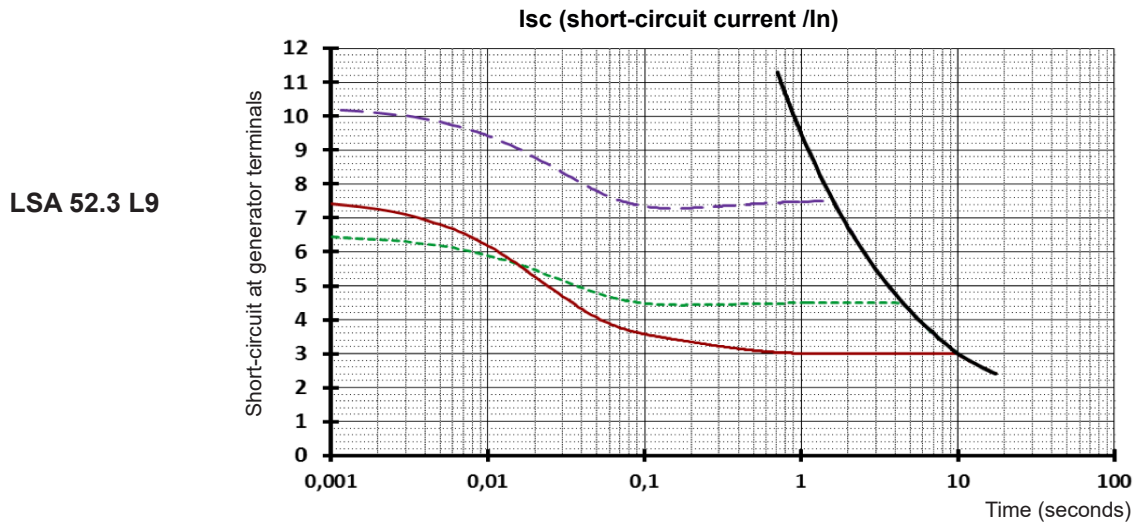

- Symmetrical phase to neutral short-circuit
- - Symmetrical two-phase short-circuit
- Symmetrical three-phase short-circuit
- Thermal limit curve

Single-bearing dimensions

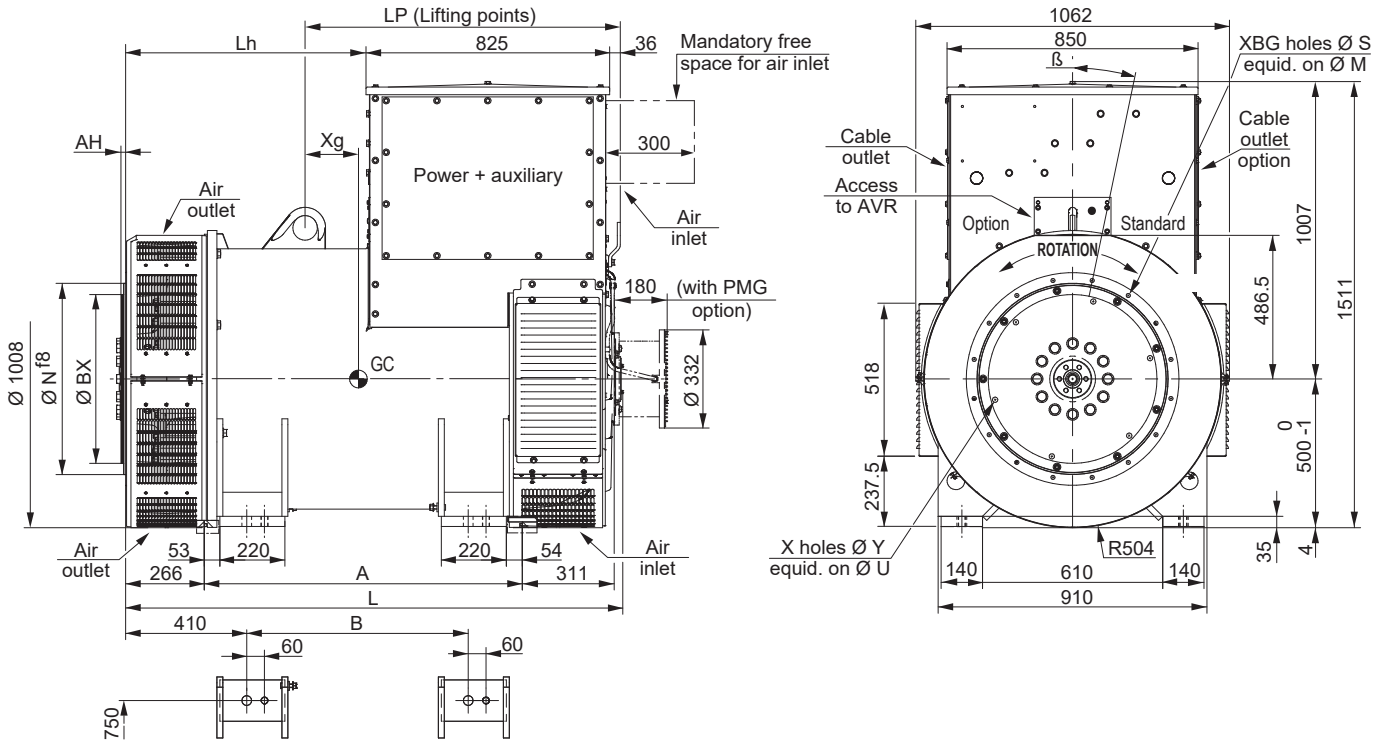

Dimensions (mm) and weight (kg)

Type	L	B	A	Lh	LP	Xg*	Weight*
LSA 52.3 S5/S6	1 683	750	1 077	814	1 067.5	175	3 748
LSA 52.3 S7	1 683	750	1 077	814	1 067.5	194	3 996
LSA 52.3 L9	1 883	950	1 277	1 014	1 067.5	64	4 446
LSA 52.3 L12	1 883	950	1 277	1 014	1 067.5	106	4 944
LSA 52.3 UL16	2 033	1 100	1 427	1 164	1 412.5	389	5 751

* Values for S.A.E. 0/18

Flange (mm)

S.A.E.	N	M	XBG	S	β°
0	647.7	679.5	16	14	11°15'
00	787.4	850.9	16	14	11°15'

Coupling

Flange S.A.E.	0	00
Flex plate S.A.E. 24		X
Flex plate S.A.E. 21		X
Flex plate S.A.E. 18	X	X

Flex plate (mm)

S.A.E.	BX	U	X	Y	AH
24	733.4	692.1	12	21	0
21	673.1	641.3	12	18	0
18	571.5	542.9	6	18	15.8

Torsional analysis data

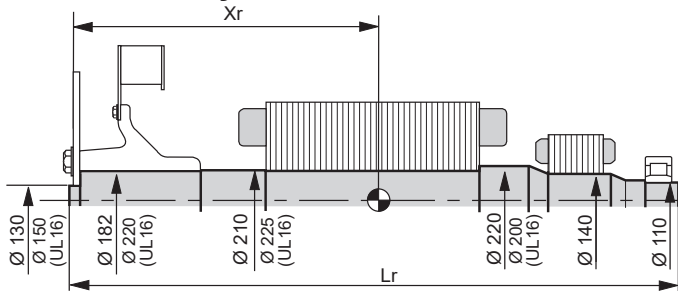

Centre of gravity: Xr (mm), Rotor length: Lr (mm), Weight: M (kg), Moment of inertia: J (kgm²) : (4J = MD²)

Flex plate	S.A.E. 18				S.A.E. 21			
	Xr	Lr	M	J	Xr	Lr	M	J
Type								
LSA 52.3 S5/S6	718	1 689	1 408	42.2	702	1 689	1 412	43.1
LSA 52.3 S7	741	1 689	1 501	45.7	725	1 689	1 505	46.6
LSA 52.3 L9	810	1 889	1 693	51	794	1 889	1 697	51.9
LSA 52.3 L12	859	1 889	1 879	58.1	843	1 889	1 883	59
LSA 52.3 UL16	954	2 039	2 188	68.5	937	2 039	2 192	69.4

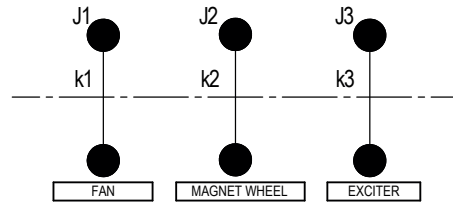

Type	S.A.E.	Torsional rigidity					
		[Nm/rad]			(kg.m²)		
		k1	k2	k3	J1	J2	J3
S5/S6	18	5.47 10E7	2.98 10E7	1.60 10E7	9.5	31.1	1.5
	21	6.66 10E7	2.98 10E7	1.60 10E7	10.4	31.1	1.5
S7	18	5.47 10E7	2.92 10E7	1.68 10E7	9.5	34.7	1.4
	21	6.66 10E7	2.92 10E7	1.68 10E7	10.4	34.7	1.4
L9	18	5.47 10E7	2.83 10E7	1.52 10E7	9.5	40	1.6
	21	6.66 10E7	2.83 10E7	1.52 10E7	10.4	40	1.6
L12	18	5.47 10E7	2.71 10E7	1.67 10E7	9.5	47.2	1.4
	21	6.66 10E7	2.71 10E7	1.67 10E7	10.4	47.2	1.4
UL16	18	5.47 10E7	2.56 10E7	1.68 10E7	9.5	57.6	1.4
	21	6.66 10E7	2.56 10E7	1.68 10E7	10.4	57.6	1.4

NOTE : Dimensions are for information only and may be subject to modifications. Contractual 2D drawings can be downloaded from the Nidec Power website, 3D drawing files are available upon request. The torsional analysis of the transmission is imperative. All values are available upon request.

Two-bearing dimensions

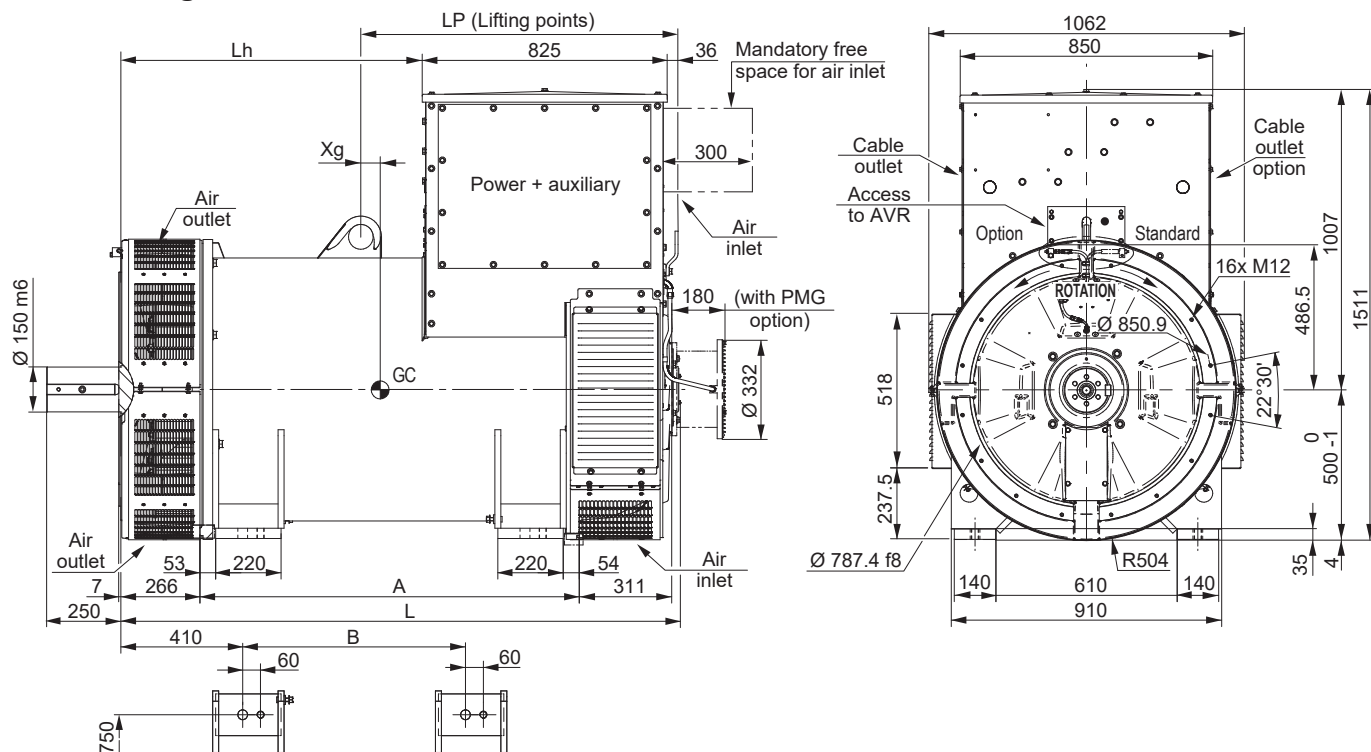

Dimensions (mm) and weight (kg)

Type	L	B	A	Lh	LP	Xg	Weight
LSA 52.3 S5/S6	1 683	750	1 077	814	1 067.5	179	3 742
LSA 52.3 S7	1 683	750	1 077	814	1 067.5	197	3 990
LSA 52.3 L9	1 883	950	1 277	1 014	1 067.5	68	4 441
LSA 52.3 L12	1 883	950	1 277	1 014	1 067.5	109	4 939
LSA 52.3 UL16	2 033	1 100	1 427	1 164	1 412	392	5 691

Torsional analysis data

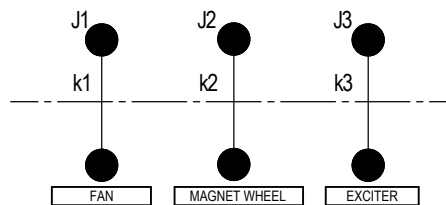
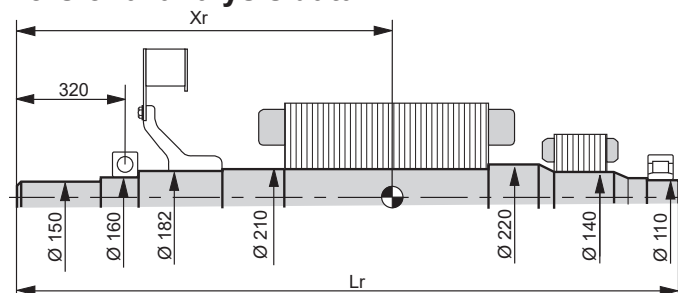

Centre of gravity: Xr (mm), Rotor length: Lr (mm), Weight: M (kg), Moment of inertia: J (kgm²) : (4J = MD²)

Type	Xr	Lr	M	J
LSA 52.3 S5/S6	977.3	1 917	1 357	40.5
LSA 52.3 S7	999.9	1 917	1 450	44
LSA 52.3 L9	1 069.1	2 117	1 642	49.4
LSA 52.3 L12	1 116.4	2 117	1 827	56.5
LSA 52.3 UL16	1 204.1	2 267	2 114	66.6

Torsional rigidity					
[Nm/rad]			(kg.m ²)		
k1	k2	k3	J1	J2	J3
1.79 E+7	3.79 E+7	1.60 E+7	7.8	31.1	1.5
1.79 E+7	3.68 E+7	1.68 E+7	7.8	34.7	1.5
1.79 E+7	3.54 E+7	1.51 E+7	7.8	40	1.6
1.79 E+7	3.36 E+7	1.67 E+7	7.8	47.2	1.5
1.79 E+7	3.13 E+7	1.32 E+7	7.8	57.5	1.3

NOTE : Dimensions are for information only and may be subject to modifications. Contractual 2D drawings can be downloaded from the Nidec Power website, 3D drawing files are available upon request.
The torsional analysis of the transmission is imperative. All values are available upon request.



www.nidecpower.com

Connect with us at:



© 2026 Moteurs Leroy-Somer SAS. The information contained in this brochure is for guidance only and does not form part of any contract. The accuracy cannot be guaranteed as Moteurs Leroy-Somer SAS have an ongoing process of development and reserve the right to change the specification of their products without notice.

Moteurs Leroy-Somer SAS. Headquarters: Bd Marcellin Leroy, CS 10015, 16915 Angoulême Cedex 9, France. Share Capital: 32,239,235 €, RCS Angoulême 338 567 258.